Analog Input Module

GT-3901 User Manual



Version 1.0

2018 CREVIS Co.,Ltd

DOCUMENT CHANGE SUMMARY				
REV	PAGE	REMARKS	DATE	EDITOR
1.0	New Document		19/01/16	JY,Hyun

Table of Contents

1. Important Notes	4
1.1. Safety Instruction	5
1.1.1. Symbols	5
1.1.2. Safety Notes	5
1.1.3. Certification	5
2. Analog Input Module List	6
3. Specification	7
3.1. GT-3901	7
3.1.1. Wiring Diagram	7
3.1.2. LED Indicator	8
3.1.3. Channel Status LED	8
3.1.4. Environment Specification	9
3.1.5. Specification	10
3.1.6. Updata cycle of process data	11
3.1.7. Mapping Data Into the Image Table	12
3.1.8. Parameter Data	22
4. Dimension	26
4.1. GT-3901(RTB)	26
5. Mounting	27
5.1. I/O Inserting and Removing Devices	27
5.2. RTB (Removable Terminal Block)	28
6. G-Bus Pin Description	29

1. Important Notes

Solid state equipment has operational characteristics differing from those of electromechanical equipment.

Safety Guidelines for the Application, Installation and Maintenance of Solid State Controls describes some important differences between solid state equipment and hard-wired electromechanical devices.

Because of this difference, and also because of the wide variety of uses for solid state equipment, all persons responsible for applying this equipment must satisfy themselves that each intended application of this equipment is acceptable.

In no event will CREVIS be responsible or liable for indirect or consequential damages resulting from the use or application of this equipment.

The examples and diagrams in this manual are included solely for illustrative purposes. Because of the many variables and requirements associated with any particular installation, CREVIS cannot assume responsibility or liability for actual use based on the examples and diagrams.

Warning!

If you don't follow the directions, it could cause a personal injury, damage to the equipment or explosion

Do not assemble the products and wire with power applied to the system. Else it may cause an electric arc, which can result into unexpected and potentially dangerous action by field devices. Arching is explosion risk in hazardous locations. Be sure that the area is non-hazardous or remove system power appropriately before assembling or wiring the modules.

Do not touch any terminal blocks or IO modules when system is running. Else it may cause the unit to an electric shock or malfunction.

Keep away from the strange metallic materials not related to the unit and wiring works should be controlled by the electric expert engineer. Else it may cause the unit to a fire, electric shock or malfunction

Caution!

If you disobey the instructions, there may be possibility of personal injury, damage to equipment or explosion. Please follow below Instructions.

Check the rated voltage and terminal array before wiring. Avoid the circumstances over 50°C of temperature. Avoid placing it directly in the sunlight.

Avoid the place under circumstances over 85% of humidity.

Do not place Modules near by the inflammable material. Else it may cause a fire.

Do not permit any vibration approaching it directly.

Go through module specification carefully, ensure inputs, output connections are made with the specifications. Use standard cables for wiring.

Use Product under pollution degree 2 environment.

1.1. Safety Instruction

1.1.1. Symbols

	Identifies information about practices or circumstances that can cause an explosion in a hazardous environment, which may lead to personal injury or death property damage, or economic loss
IMPORTANT	Identifies information that is critical for successful application and understanding of the product
ATTENTION 	Identifies information about practices or circumstances that can lead to personal injury, property damage, or economic loss. Attentions help you to identity a hazard, avoid a hazard, and recognize the consequences

1.1.2. Safety Notes

DANGER 	The modules are equipped with electronic components that may be destroyed by electrostatic discharge. When handling the modules, ensure that the environment (persons, workplace and packing) is well grounded. Avoid touching conductive components, G-BUS Pin.
--	--

1.1.3. Certification

c-UL-us UL Listed Industrial Control Equipment, certified for U.S. and Canada

See UL File E235505

CE Certificate

EN 61000-6-2; Industrial Immunity

EN 61000-6-4; Industrial Emissions

Reach, RoHS (EU, CHINA)

2. Analog Input Module List

GT-Number	Description	ID
GT-3901	3Phase, AC Measurement, Lx-Ly 500Vac/1A	3901

3. Specification

3.1. GT-3901

3.1.1. Wiring Diagram

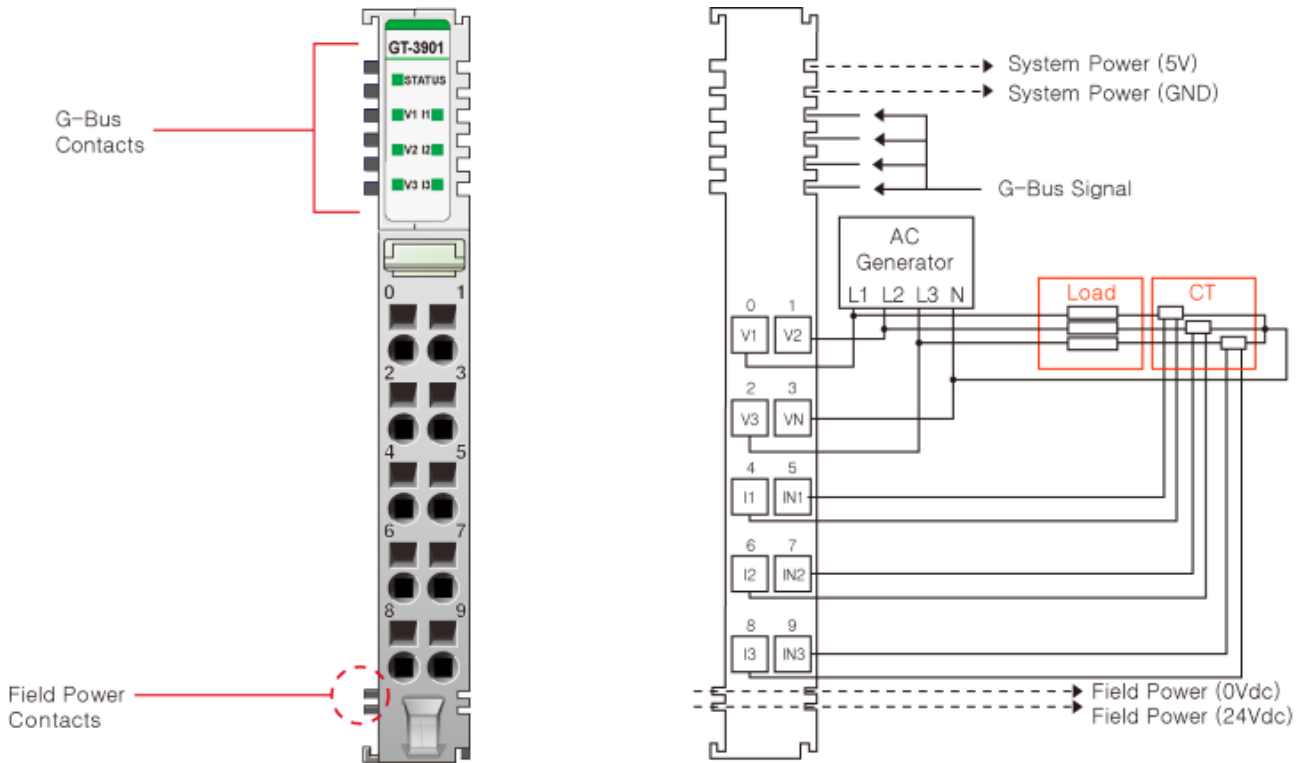

Pin No.	Signal Description	Signal Description	Pin No.
0	Voltage Input 0 (L1)	Voltage Input 1 (L2)	1
2	Voltage Input 2 (L3)	Voltage Input Common (Neutral)	3
4	Current Input L1	Current Input N1	5
6	Current Input L2	Current Input N2	7
8	Current Input L3	Current Input N3	9

3.1.2. LED Indicator

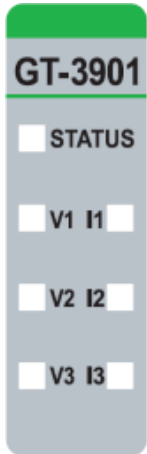

LED No.	LED Function / Description	LED Color
0	Status	Green
1	Voltage Input Channel 1	Green
2	Current Input Channel 1	Green
3	Voltage Input Channel 2	Green
4	Current Input Channel 2	Green
5	Voltage Input Channel 3	Green
6	Current Input Channel 3	Green

3.1.3. Channel Status LED

Status	LED	To indicate
Over Voltage	Voltage Input LED : OFF	Error Occurred
	Voltage Input LED : Green	Normal Operation
Under Voltage	Voltage Input LED : OFF	Error Occurred
	Voltage Input LED : Green	Normal Operation
Over Current	Current Input LED : OFF	Error Occurred
	Current Input LED : Green	Normal Operation
No Signal	Voltage Input LED : OFF Current Input LED : OFF	Error Occurred
	Voltage Input LED : Green Current Input LED : Green	Normal Operation
G-Bus Status	Status LED : OFF	Disconnection
	Status LED : Green	Connection

* Please refer to Input Image Data.(Error Byte)

3.1.4. Environment Specification

Environmental Specification	
Operation Temperature	-40°C ~ 70°C
UL Temperature	-20°C ~ 60°C
Storage Temperature	-40°C ~ 85°C
Relative Humidity	5% ~ 90% Non-condensing
Operation Altitude	2,000m
Mounting	DIN Rail
General Specification	
Shock Operating	IEC 60068-2-27
Vibration Resistance	Sine Vibration (Based on IEC 60068-2-6) - 5 ~ 25Hz : ±1.6mm - 25 ~ 300Hz : 4g - Sweep Rate : 1 Oct/min, 20 Sweeps Random Vibration - 10 ~ 40 Hz : 0.0125 g ² /Hz - 40 ~ 100 Hz : 0.0125 → 0.002 g ² /Hz - 100 ~ 500 Hz : 0.002 g ² /Hz - 500 ~ 2000 Hz : 0.002 → 1.3 x 10-4g ² /Hz - Test time : 1hrs for each test
EMC Resistance Burst/ESD	EN 61000-6-2 : 2005 EN61000-6-4/All : 2011
Installation Pos./Protect. Class	Variable/IP20
Product Certifications	CE, UL

3.1.5. Specification

Items	Specification
Input Specification	
Number of Channel	3 Ch Voltage Input, 3 Ch Current Input via CT
Indicators	1 Green Status LEDs 3 LEDs : VL1, VL2, VL3 3 LEDs : IL1, IL2, IL3
Input Voltage Range	$V_{LN} = 288VAC$, $V_{LL} = 500VAC$
Input Resistance voltage path	1200K Ω
Measuring Current	1A (MAX), CT 1: 4000(MAX)
Input resistance current path	30mg Ω
Resolution	24bits
Input Frequency range	45Hz ~ 65Hz
Measured values	Angle, Voltage, Current, Power, Energy, Frequency, Power Factors
Measuring error	Voltage&Current = 0.5% @ -20 $^{\circ}C$ ~50 $^{\circ}C$ Voltage&Current = 1% @ -20 $^{\circ}C$ ~60 $^{\circ}C$ Voltage&Current = 1.5% @ -20 $^{\circ}C$ ~70 $^{\circ}C$ Frequency = $\pm 0.1Hz$ Phase angle = $\pm 0.6^{\circ}$
General Specification	
Power Dissipation	Max. 125 mA @ 5Vdc
Isolation	I/O to Logic : Photocoupler Isolation Field power : Non-Isolation
Field Power	Supply Voltage : 24Vdc nominal Voltage Range : 18 ~ 32Vdc Power Dissipation : 0mA @ 32Vdc
Wiring	I/O Cable Max. 2.0mm ² (AWG 14)
Weight	63g
Module Size	12mm x 109mm x 70mm
Environment Condition	Refer to 'Environment Specification'

* The measuring accuracy is reduced, if the extended temperature range is used(-40 $^{\circ}C$ ~70 $^{\circ}C$)

* If the input value is small, the error of calculation value can be large.

(Please input 10% or more of the Whole range)

3.1.6. Updata cycle of process data

Read Data	Updata Time
	Max
Rms Voltage	300us
Max. Rms Voltage	300us
Min. Rms Voltage	300us
Rms Current	300us
Max. Rms Current	300us
Min. Rms Current	300us
Apparent Power	250us
Active Power	350us
Max. Active Power	350us
Min. Active Power	350us
Reactive Power	2000us
Apparent Energy	100ms
Total Apparent Energy	100ms
Active Energy	100ms
Total Active Energy	100ms
Reactive Energy	100ms
Total Reavitve energy	100ms
Cos phi	200us
Supply Network Frequency	200us
Max. Supply Network Frequency	200us
Min. Supply Network Frequency	200us
Phase Angle phi	300us

3.1.7. Mapping Data into the Image Table

Byte	Output Data	Input Data	
0	Control byte 0	Status byte 0	
1	Control byte 1	Status byte 1	
2	Control byte 2	Status byte 2	
3	Control byte 3	Status byte 3	
4	Not used	Error byte 0	
5		Error byte 1	
6		Error byte 2	
7		Reserved	
8		Process value 1	
9			
10			
11			
12		Process value 2	
13			
14			
15			
16		Process value 3	
17			
18			
19			
20	Process value 4		
21			
22			
23			

● Input Image Value

Status byte 0							
Bit 7	Bit 6	Bit 5	Bit 4	Bit 3	Bit 2	Bit 1	Bit 0
RES	Measure Select			CON_ID			
Measure Select		0 = Voltage 1 = Current 2 = Power 3 = PF 4 = Phase Angle 5 = Frequency 6 = Energy 7 = reserved					
RES		Resetting all of the min/max/energy values					
CON_ID		CON_ID					
Status byte 1							
Bit 7	Bit 6	Bit 5	Bit 4	Bit 3	Bit 2	Bit 1	Bit 0
reserved	Measure Select			CON_ID			
Measure select		0 = Voltage 1 = Current 2 = Power 3 = PF 4 = Phase Angle 5 = Frequency 6 = Energy 7 = reserved					
CON_ID		CON_ID					
Status byte 2							
Bit 7	Bit 6	Bit 5	Bit 4	Bit 3	Bit 2	Bit 1	Bit 0
reserved	Measure Selcset			CON_ID			
Measure Select		0 = Voltage 1 = Current 2 = Power 3 = PF 4 = Phase Angle 5 = Frequency 6 = Energy 7 = reserved					
CON_ID		CON_ID					
Status byte 3							
Bit 7	Bit 6	Bit 5	Bit 4	Bit 3	Bit 2	Bit 1	Bit 0
reserved	Measure Selcset			CON_ID			
Measure Select		0 = Voltage 1 = Current					

	2 = Power 3 = PF 4 = Phase Angle 5 = Frequency 6 = Energy 7 = reserved
CON_ID	CON_ID

Error byte 0							
Bit 7	Bit 6	Bit 5	Bit 4	Bit 3	Bit 2	Bit 1	Bit 0
ERR_VL2	VL2_Error code			ERR_VL1	VL1_Error code		
ERR_VL1	Phase 1 Voltage Input ERROR 0 = OK 1 = Error occurred						
ERR_VL2	Phase 2 Voltage Input ERROR 0 = OK 1 = Error occurred						
Error byte 1							
Bit 7	Bit 6	Bit 5	Bit 4	Bit 3	Bit 2	Bit 1	Bit 0
ERR_IL1	IL1_Error code			ERR_VL3	VL3_Error code		
ERR_VL3	Phase 3 Voltage Input ERROR 0 = OK 1 = Error occurred						
ERR_IL1	Phase 1 Current Input ERROR 0 = OK 1 = Error occurred						
Error byte 2							
BBit 7	Bit 6	Bit 5	Bit 4	Bit 3	Bit 2	Bit 1	Bit 0
ERR_IL3	IIL3_Error code			ERR_IL2	IL2_Error code		
ERR_IL2	Phase 2 Current Input ERROR 0 = OK 1 = Error occurred						
ERR_IL3	Phase 3 Current Input ERROR 0 = OK 1 = Error occurred						
Error code	0 = No Error 1 = Over Input 2 = Under Input 3 = No Connect						

Process value 0-0 Byte							
Bit 7	Bit 6	Bit 5	Bit 4	Bit 3	Bit 2	Bit 1	Bit 0
Proc0[7 : 0]							
Proc0[7 : 0]		Process value 0 of Status Byte 0					
Process value 0-1 Byte							
Bit 7	Bit 6	Bit 5	Bit 4	Bit 3	Bit 2	Bit 1	Bit 0
Proc0[15 : 8]							
Proc0[15 : 8]		Process value 0 of Status Byte 0					
Process value 0-2 Byte							
Bit 7	Bit 6	Bit 5	Bit 4	Bit 3	Bit 2	Bit 1	Bit 0
Proc0[23 : 16]							
Proc0[23 : 16]		Process value 0 of Status Byte 0					
Process value 0-3 Byte							
Bit 7	Bit 6	Bit 5	Bit 4	Bit 3	Bit 2	Bit 1	Bit 0
Proc0[31 : 24]							
Proc0[31 : 24]		Process value 0 of Status Byte 0					
Process value 1-0 Byte							
Bit 7	Bit 6	Bit 5	Bit 4	Bit 3	Bit 2	Bit 1	Bit 0
Proc1[7 : 0]							
Proc1[7 : 0]		Process value 1 of Status Byte 1					
Process value 1-1 Byte							
Bit 7	Bit 6	Bit 5	Bit 4	Bit 3	Bit 2	Bit 1	Bit 0
Proc1[15 : 8]							
Proc1[15 : 8]		Process value 1 of Status Byte 1					
Process value 1-2 Byte							
Bit 7	Bit 6	Bit 5	Bit 4	Bit 3	Bit 2	Bit 1	Bit 0
Proc1[23 : 16]							
Proc1[23 : 16]		Process value 1 of Status Byte 1					
Process value 1-3 Byte							

Bit 7	Bit 6	Bit 5	Bit 4	Bit 3	Bit 2	Bit 1	Bit 0
Proc1[31 : 24]							
Proc1[31 : 24]		Process value 1 of Status Byte 1					
Process value 2-0 Byte							
Bit 7	Bit 6	Bit 5	Bit 4	Bit 3	Bit 2	Bit 1	Bit 0
Proc2[7 : 0]							
Proc2[7 : 0]		Process value 2 of Status Byte 2					
Process value 2-1 Byte							
Bit 7	Bit 6	Bit 5	Bit 4	Bit 3	Bit 2	Bit 1	Bit 0
Proc1[15 : 8]							
Proc2[15 : 8]		Process value 2 of Status Byte 2					
Process value 2-2 Byte							
Bit 7	Bit 6	Bit 5	Bit 4	Bit 3	Bit 2	Bit 1	Bit 0
Proc1[23 : 16]							
Proc2[23 : 16]		Process value 2 of Status Byte 2					
Process value 2-3 Byte							
Bit 7	Bit 6	Bit 5	Bit 4	Bit 3	Bit 2	Bit 1	Bit 0
Proc1[31 : 24]							
Proc2[31 : 24]		Process value 2 of Status Byte 2					
Process value 3-0 Byte							
Bit 7	Bit 6	Bit 5	Bit 4	Bit 3	Bit 2	Bit 1	Bit 0
Proc3[7 : 0]							
Proc3[7 : 0]		Process value 3 of Status Byte 3					
Process value 3-1 Byte							
Bit 7	Bit 6	Bit 5	Bit 4	Bit 3	Bit 2	Bit 1	Bit 0
Proc3[15 : 8]							
Proc3[15 : 8]		Process value 3 of Status Byte 3					
Process value 3-2 Byte							
Bit 7	Bit 6	Bit 5	Bit 4	Bit 3	Bit 2	Bit 1	Bit 0
Proc3[23 : 16]							

Proc3[23 : 16]		Process value 3 of Status Byte 3					
Process value 3-3 Byte							
Bit 7	Bit 6	Bit 5	Bit 4	Bit 3	Bit 2	Bit 1	Bit 0
Proc3[31 : 24]							
Proc3[31 : 24]		Process value 3 of Status Byte 3					

● Output Image Value

Control byte 0							
Bit 7	Bit 6	Bit 5	Bit 4	Bit 3	Bit 2	Bit 1	Bit 0
RESET	Measure Select			CON_ID			
Measure Select		0 = Voltage 1 = Current 2 = Power 3 = PF 4 = Phase Angle 5 = Frequency 6 = Energy 7 = reserved					
RESET		Resetting all of the min/max/energy values					
CON_ID		CON_ID					
Control byte 1							
Bit 7	Bit 6	Bit 5	Bit 4	Bit 3	Bit 2	Bit 1	Bit 0
reserved	Measure Select			CON_ID			
Measure select		0 = Voltage 1 = Current 2 = Power 3 = PF 4 = Phase Angle 5 = Frequency 6 = Energy 7 = reserved					
CON_ID		CON_ID					
Control byte 2							
Bit 7	Bit 6	Bit 5	Bit 4	Bit 3	Bit 2	Bit 1	Bit 0
reserved	Measure Selcet			CON_ID			
Measure Select		0 = Voltage 1 = Current 2 = Power 3 = PF 4 = Phase Angle 5 = Frequency 6 = Energy 7 = reserved					
CON_ID		CON_ID					
Control byte 3							
Bit 7	Bit 6	Bit 5	Bit 4	Bit 3	Bit 2	Bit 1	Bit 0
reserved	Measure Selcet			CON_ID			
Measure Select		0 = Voltage 1 = Current					

	2 = Power 3 = PF 4 = Phase Angle 5 = Frequency 6 = Energy 7 = reserved		
CON_ID	CON_ID		
CON_ID	Measured Value	Data Type	Scaling
Measure Select = Voltage			
00	RMS Voltage L1-N	Uint32	0.01V
01	RMS Voltage L2-N	Uint32	0.01V
02	RMS Voltage L3-N	Uint32	0.01V
03	Max. RMS Voltage L1-N	Uint32	0.01V
04	Max. RMS Voltage L2-N	Uint32	0.01V
05	Max. RMS Voltage L3-N	Uint32	0.01V
06	Min. RMS Voltage L1-N	Uint32	0.01V
07	Min. RMS Voltage L2-N	Uint32	0.01V
08	Min. RMS Voltage L3-N	Uint32	0.01V
09	reserved		
0A			
0B			
0C			
0D			
0E			
0F			
CON_ID	Measured Value	Data Type	Scaling
Measure Select = Current			
00	RMS Current L1-N	Uint32	0.001A
01	RMS Current L2-N	Uint32	0.001A
02	RMS Current L3-N	Uint32	0.001A
03	Max. RMS Current L1-N	Uint32	0.001A
04	Max. RMS Current L2-N	Uint32	0.001A
05	Max. RMS Current L3-N	Uint32	0.001A
06	Min. RMS Current L1-N	Uint32	0.001A
07	Min. RMS Current L2-N	Uint32	0.001A
08	Min. RMS Current L3-N	Uint32	0.001A
09	reserved		
0A			
0B			
0C			
0D			
0E			
0F			
CON_ID	Measured Value	Data Type	Scaling
Measure Select = Power			
00	Apparent power L1	Uint32	0.01VA

01	Apparent power L2	Uint32	0.01VA
02	Apparent power L3	Uint32	0.01VA
03	Active power L1	Int32	0.01W
04	Active power L2	Int32	0.01W
05	Active power L3	Int32	0.01W
06	Max. active power L1	Int32	0.01W
07	Max. active power L2	Int32	0.01W
08	Max. active power L3	Int32	0.01W
09	Min. active power L1	Int32	0.01W
0A	Min. active power L2	Int32	0.01W
0B	Min. active power L3	Int32	0.01W
0C	Reactive power L1	Int32	0.01VAR
0D	Reactive power L2	Int32	0.01VAR
0E	Reactive power L3	Int32	0.01VAR
CON_ID	Measured Value	Data Type	Scaling
Measure Select = Energy			
00	Apparent energy L1	Uint32	Set the Parameter
01	Apparent energy L2	Uint32	
02	Apparent energy L3	Uint32	
03	Total Apparent Energy	Uint32	
04	Active energy L1	Int32	
05	Active energy L2	Int32	
06	Active energy L3	Int32	
07	Total Active Energy	Int32	
08	Reactive Energy L1	Int32	
09	Reactive Energy L2	Int32	
0A	Reactive Energy L3	Int32	
0B	Total Reactive Energy	Int32	
0C	reserved		
0D			
0E			
0F			
CON_ID	Measured Value	Data Type	Scaling
Measure Select = Power Factor			
00	Power Factor L1	Int32	0.01
01	Power Factor L2	Int32	0.01
02	Power Factor L3	Int32	0.01
03	Reserved		
04			
05			
06			
07			
08			
09			
0A			
0B			

0C			
0D			
0E			
0F			
CON_ID	Measured Value	Data Type	Scaling
Measure Select = Frequency			
00	Supply network frequency L1	uint32	0.01Hz
01	Supply network frequency L2	uint32	0.01Hz
02	Supply network frequency L3	uint32	0.01Hz
03	Max. Supply network frequency L1	uint32	0.01Hz
04	Max. Supply network frequency L2	uint32	0.01Hz
05	Max. Supply network frequency L3	uint32	0.01Hz
06	Min. Supply network frequency L1	uint32	0.01Hz
07	Min. Supply network frequency L2	uint32	0.01Hz
08	Min. Supply network frequency L3	uint32	0.01Hz
09			
0A			
0B			
0C			
0D			
0E			
CON_ID	Measured Value	Data Type	Scaling
Measure Select = Phase angle			
00	Phase angle phi L1	uint32	0.01 °
01	Phase angle phi L2	uint32	0.01 °
02	Phase angle phi L3	uint32	0.01 °
03			
04			
05			
06			
07			
08			
09			
0A			
0B			
0C			
0D			
0E			
0F			

3.1.8. Parameter Data

· Valid Parameter length : 5 Bytes

· Parameter Data

	Bit#7	Bit#6	Bit#5	Bit#4	Bit#3	Bit#2	Bit#1	Bit#0
Byte#0	CT sensor 1 : x							
	Value for the current transformer ratio divisor							
	Bit#7	Bit#6	Bit#5	Bit#4	Bit#3	Bit#3	Bit#2	Bit#1
Byte#1	Frequency	scaling for energy values			CT sensor 1 : x			
	0= 45 ~ 55Hz	0= 1m Wh/VARh/VAh			Value for the current transformer ratio divisor			
	1= 55 ~ 65Hz	1= 0.01 Wh/VARh/VAh						
		2= 0.1 Wh/VARh/VAh						
		3= 1 Wh/VARh/VAh						
		4= 0.01k Wh/VARh/VAh						
		5= 0.1k Wh/VARh/VAh						
		6= 1k Wh/VARh/VAh						
	7= reserved							
	Bit#7	Bit#6	Bit#5	Bit#4	Bit#3	Bit#3	Bit#2	Bit#1
Byte#2	Overvoltage threshold Lx (value) Resolution 0.2V							
	Overvoltage threshold = 250V+value*0.2V. (MAX 300V)							
	Bit#7	Bit#6	Bit#5	Bit#4	Bit#3	Bit#3	Bit#2	Bit#1
Byte#3	Undervoltage threshold Lx (value) Resolution 0.5V							
	Undervoltage threshold = 0V+value*0.5V. (MAX 125V)							
	Bit#7	Bit#6	Bit#5	Bit#4	Bit#3	Bit#3	Bit#2	Bit#1
Byte#4	Overcurrent threshold Lx (value) Resolution 2mA							
	Overcurrent threshold = 0.8A+value*0.002A. (MAX 1.3A)							

* Set Frequency to get the correct Power Factor & Energy.

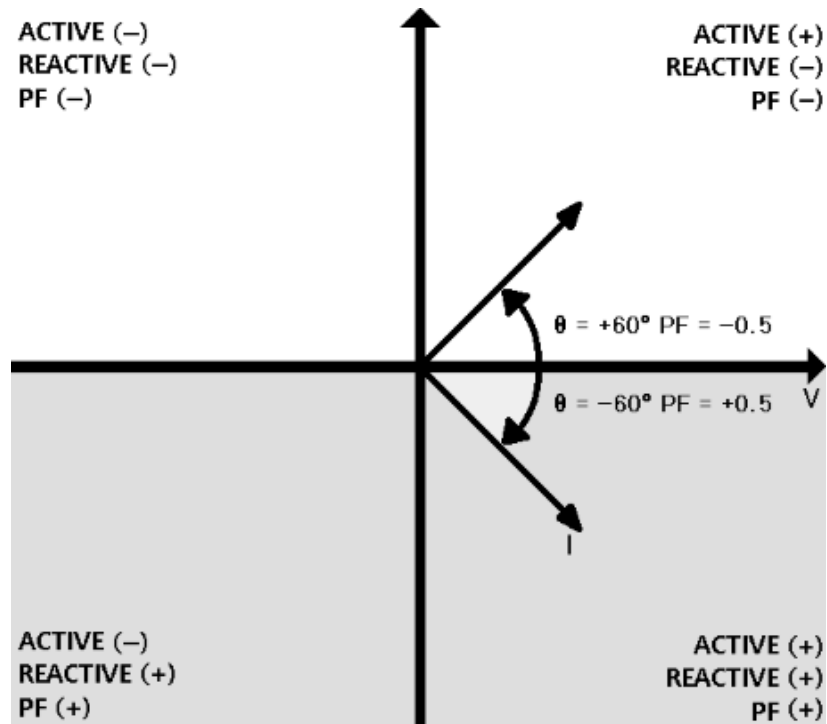

*the reactive power measurement is negative when the load is capacitive, and when the load is inductive.

The sign of the reactive power can therefore be used to reflect the sign of the power factor.

Power Factor = (Sign Fundamental Reactive Power) * (abs(Active Power)/Apparent Power)

● **Example of Setting**

- Read data : Phase 1 Rms Voltage/Rms Current/Apparent power/Active power.
- Input Value : 220V, 1000A, PF 0.5
- Parameter : CT 1 : 1000, Input Frequency 55 ~ 65Hz, Overvoltage threshold 260V, Other is Default(0).
- Overvoltage Threshold = (260V(User Setting Value)-250V(defaultSetting Value))/0.2V. Resolution : 0.2V
- ex) OverCurrent Threshold = 1000A (User Setting CT 1 : 1000)=((1A(User Setting Value)-0.8(default Setting Value))/0.001)*1000(CT).Resolution : 0.001A
- * All of default value is 0

- **Step #1**

- Set the Parameter

Parameter	Value
CT sensor 1 : x (12 bit)	001111101000(bit) Set CT 1000
Scaling for energy values (3 bit)	000 (bit) Set 1 m Wh/VARh/VAh
Frequency (1 bit)	1 (bit) Set 55~65Hz
Overvoltage Threshold Lx (8 bit)	00110010 (bit) Set 260V
Undervoltage threshold Lx (8 bit)	00000000 (bit) Set 0V(default)
Overcurrent Threshold Lx (8 bit)	00000000 (bit) Set 0.8A(default)
All of Parameter	E8 83 32 00 00 (Byte hex)

- **Setp #2**

- Set the Control Byte (See Output Image Value)

	Bit# 7	Bit# 6	Bit# 5	Bit# 4	Bit# 3	Bit# 2	Bit# 1	Bit# 0
Control Byte #0	RES	Measure Select (Voltage)			CON_ID (Rms Voltage L1-N)			
	0	0	0	0	0	0	0	0
Control Byte #1	RES	Measure Select (Current)			CON_ID (Rms Current L1-N)			
	0	0	0	1	0	0	0	0
Control Byte #2	RES	Measure Select (Power)			CON_ID (Apparent Power L1)			
	0	0	0	2	0	0	0	0
Control Byte #3	RES	Measure Select (Power)			CON_ID (Active Power L1)			
	0	0	0	2	0	0	1	1

- Setp #3

- Check the Status Byte, When Status Byte and Control Byte are same, the Process value is updated.

	Bit# 7	Bit# 6	Bit# 5	Bit# 4	Bit# 3	Bit# 2	Bit# 1	Bit# 0
Status Byte #0	RES	Measure Select (Voltage)			CON_ID (Rms Voltage L1-N)			
	0	0	0	0	0	0	0	0
Status Byte #0	RES	Measure Select (Current)			CON_ID (Rms Current L1-N)			
	0	0	0	1	0	0	0	0
Status Byte #0	RES	Measure Select (Power)			CON_ID (Apparent Power L1)			
	0	0	0	2	0	0	0	0
Status Byte #0	RES	Measure Select (Power)			CON_ID (Active Power L1)			
	0	0	0	2	0	0	1	1

- Step #4

- Check the Process value

Process value #0 (Rms Voltage)	000055F0 (Dword hex) 22000 (Dec) 220V
Process value #0 (Rms Current)	000F4240 (Dword hex) 1000000 (Dec) 1000A
Process value #0 (Apparent power)	014FB180 (Dword hex) 22000000 (Dec) 220kVA
Process value #0 (Active power)	00A7D8C0 (Dword hex) 11000000 (Dec) 110kW

4. Dimension

4.1. GT-3901(RTB)

(mm)

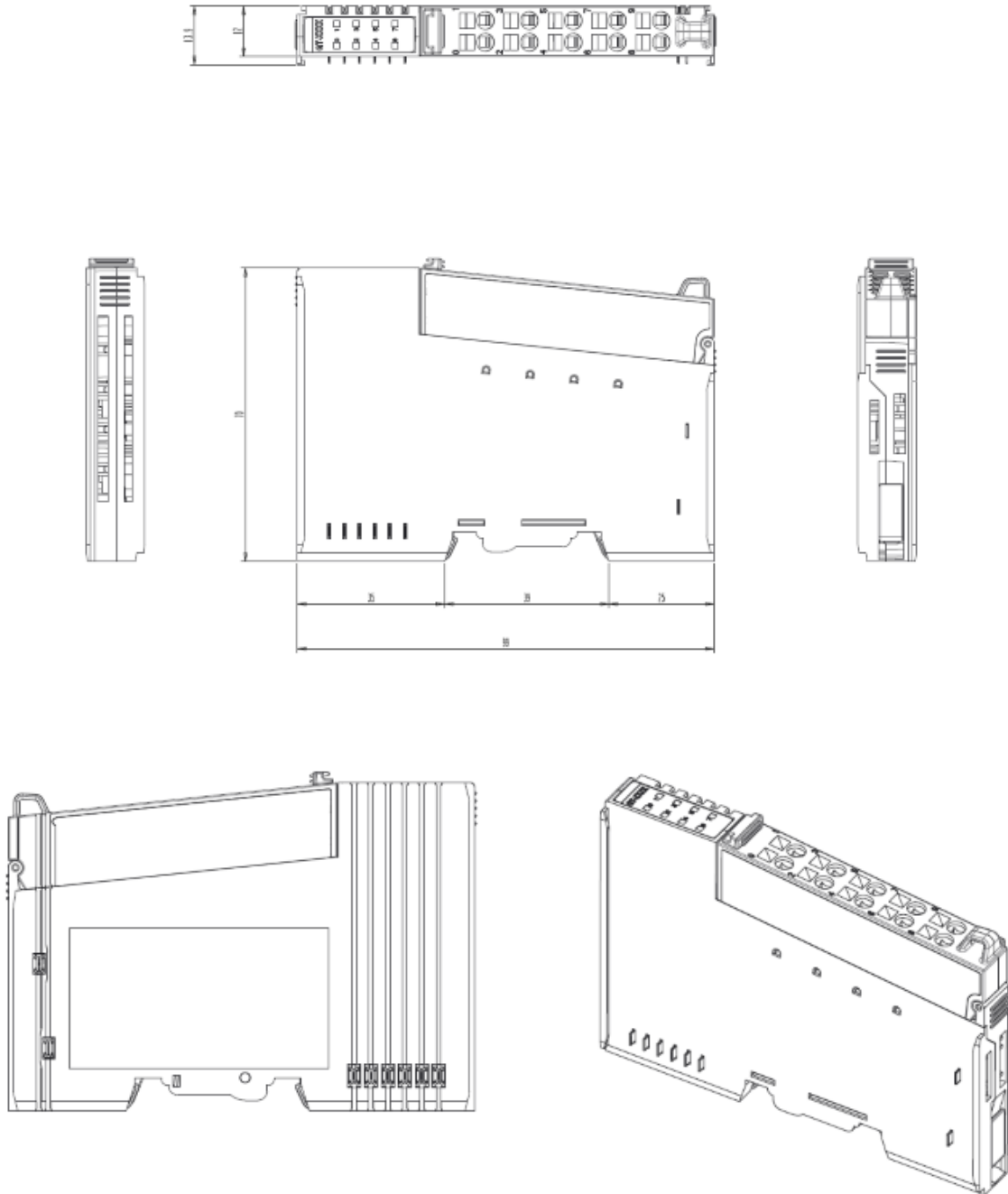

5. Mounting

Caution!

Hot surface!

The surface of the housing can become hot during operation. If the device was operated at high ambient temperatures, allow it to be cool before touching it.

Notice!

Perform work on devices only if they are de-energized!

Working on energized devices can damage them. Therefore, turn off the power supply before working on the devices.

5.1. I/O Inserting and Removing Devices

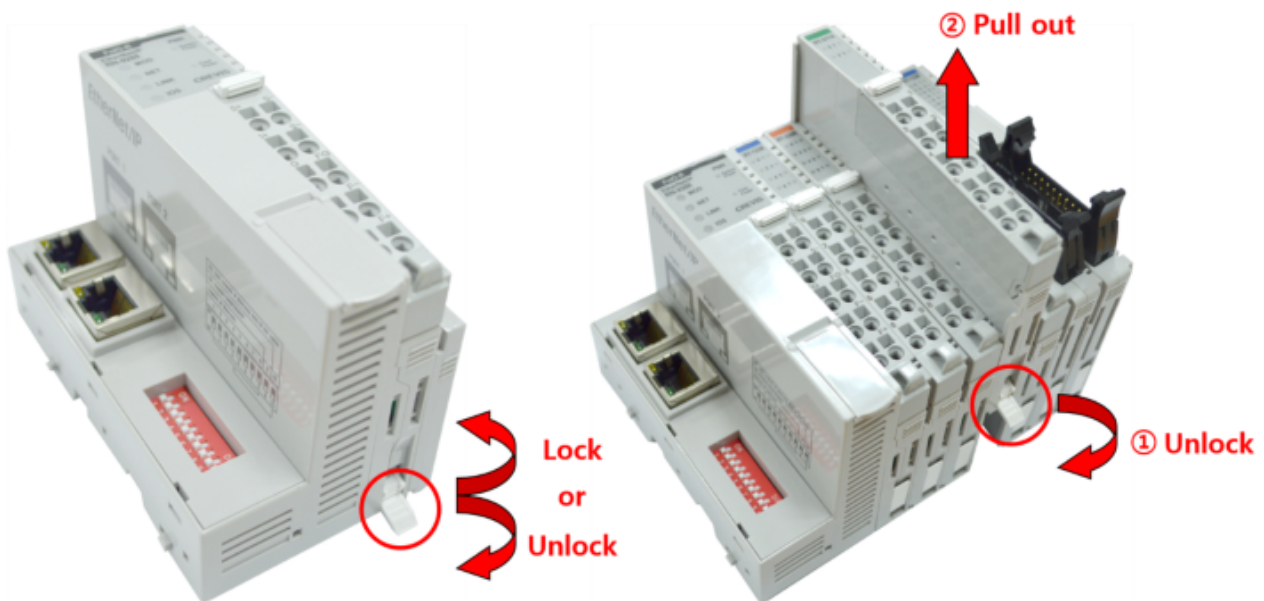

- As above figure in order to safeguard the G-Series module from jamming, it should be fixed onto the DIN rail with locking level. To do so, fold on the upper of the locking lever. To pull out the G-Series module, unfold the locking lever as below figure.

5.2. RTB (Removable Terminal Block)

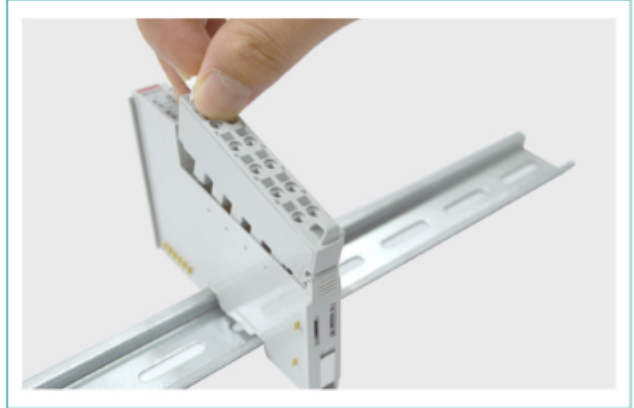
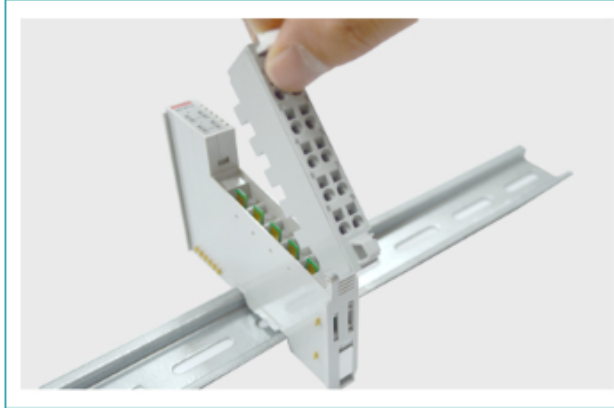
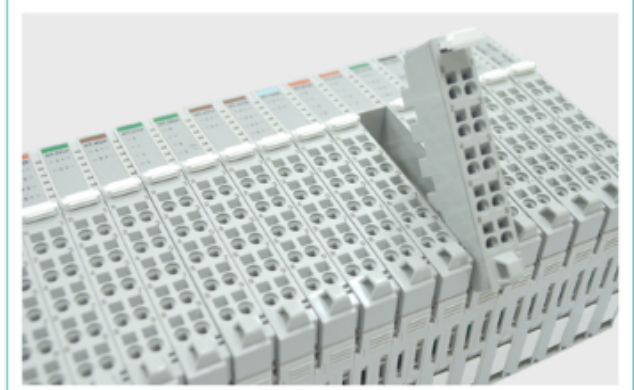
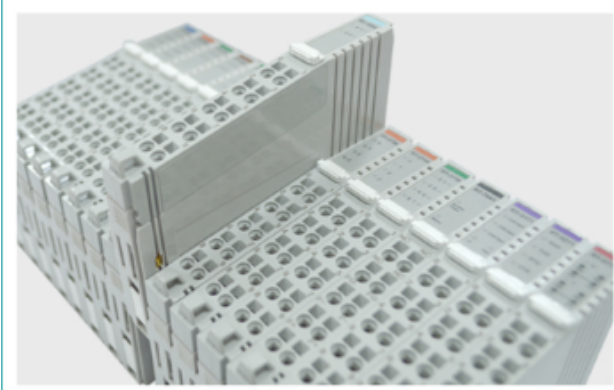

Whole terminal block can be combined and removed for the convenience.

There is a locking switch on the RTB for the easy combination and easy removal.

Easy combination and easy removal for IO modules on the din rail through One Touch Locking Switch.

6. G-Bus Pin Description

Communication between the GN series and the expansion module as well as system / field power supply of the bus modules is carried out via the internal bus. It is comprised of 6 data pin and 2 field power pin.

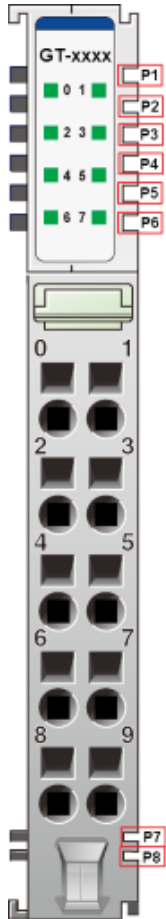

*Please refer to the table below regarding the pin description from P1 to P8.

No.	Description
P1	System Power (VCC)
P2	System Power (GND)
P3	GBUS TX +
P4	GBUS TX -
P5	GBUS RX +
P6	GBUS RX -
P7	Field Power (GND)
P8	Field Power (VCC)

Do not touch data and field power pins in order to avoid soiling and damage by ESD noise.